

Thintanks

2000 LITRE INSTALLATION INSTRUCTIONS

FREESTANDING

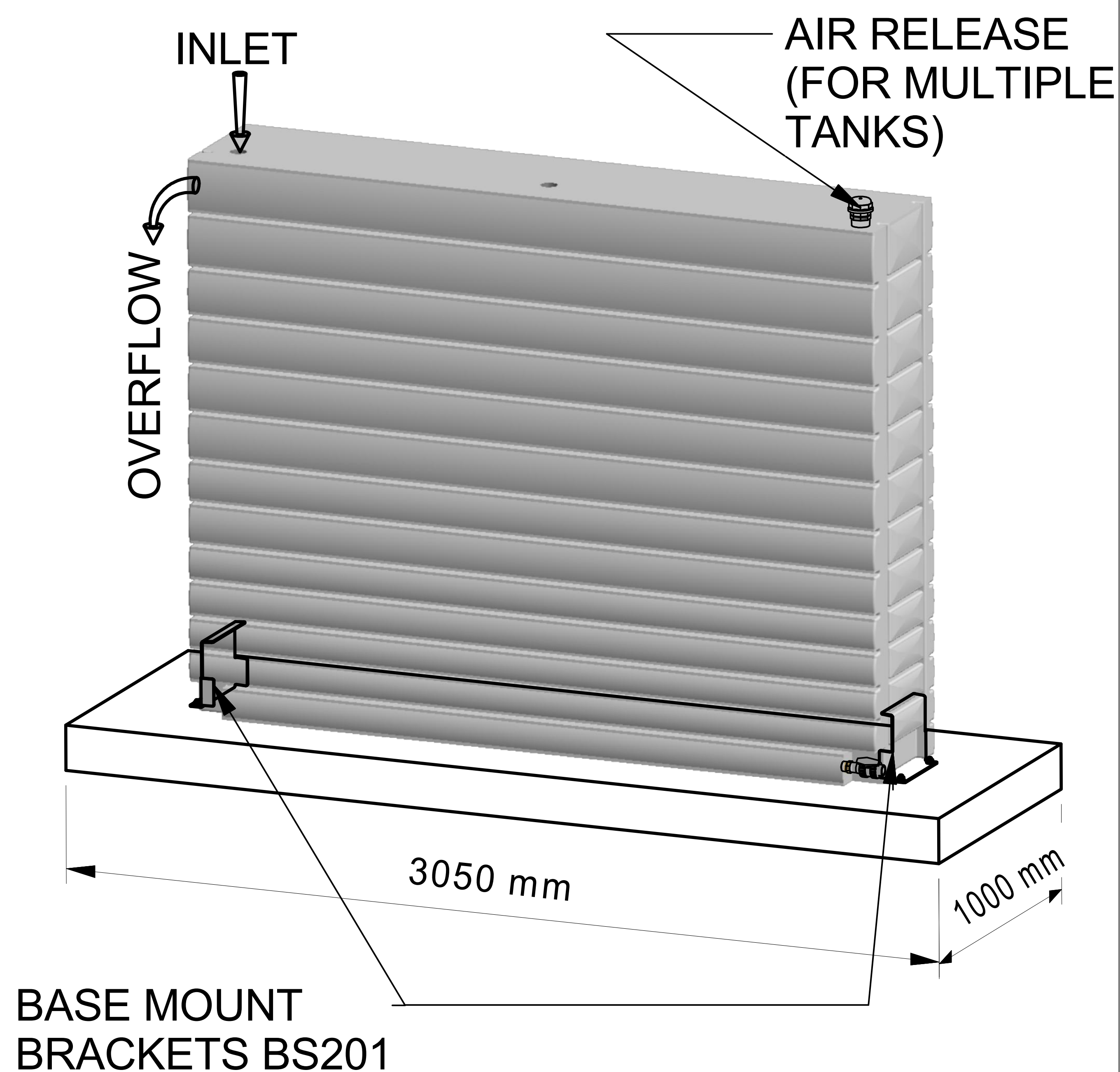

WALL MOUNTED

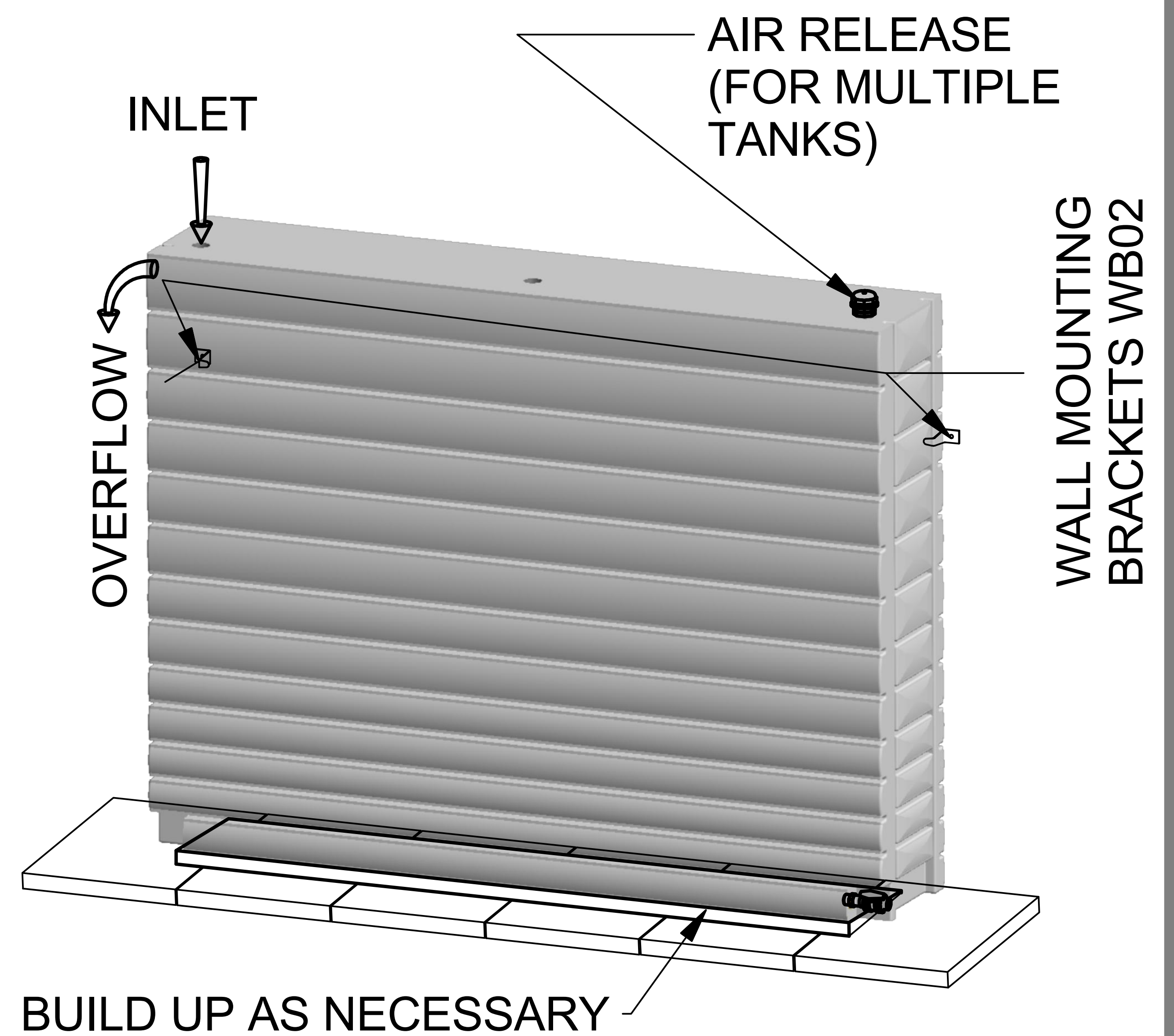

THIN TANK INSTALLATION.

It is important for tanks to stand on a solid base, that will not settle or move when wet.

The tank(s) can be laid on sloping ground, along the length of the tank.

Surface must be horizontal across the width of the tank to allow the sides of the tank to be vertical.

2000 litre tank - Freestanding.

Form and pour 150mm thick concrete slab, 1000mm wide with 150mm overlap on ends.

Use F82 fabric placed centrally 75mm above prepared surface.

Use a carpenter's level to make sure the concrete surface is level across the width.

Secure tank to the concrete using brackets BS201 - one each end.

With multiple tanks use bracket BSD201 between tanks.

2000 litre tank - Wall mounting.

On an existing pavement, sloping away from a fence or wall, the surface must be built up to ensure the tank face is vertical and the back of the tank is flush against the fence or wall. See diagram.

Position first tank on the prepared base and fix to fence, or wall, using bracket WB02 each end. For multiple tanks use bracket WBD02 between tanks. Place brackets approximately 1400mm above base. Brackets are required to ensure tank(s) cannot be accidentally pulled over by human effort.

WARRANTY Thintanks warrants its tanks by a pro rata warranty for 10 years from the original date of purchase. This warranty covers the original purchaser only and is not transferable. Thintanks will repair or replace, at its discretion the tank affected by a defect caused by the manufacturing process or materials. Fading or colour change, damage caused by accidents or misuse, do-it-yourself repairs or incorrect installation, and any subsequent costs (including freight of replacement tank) are not covered by warranty.